



# commercial 1000

The **1000 Commercial Series** come pre-assembled with the brackets and tensioner, which significantly reduces installation time and saves money. The **1000 Series** is designed for dependability and ease of installation, an economical investment for light commercial use. If the reduced-drive chain hoist operation (RH only) is selected, the door is delivered with brackets, tensioner, and gears. The chain-drive is not pre-assembled to the door.



**Maximum  
12' x 14'**

Available in sizes up to 12' x 14' and in more than 30 colors, customized for your application.



**Light-Duty  
Application**

Ideal for light-duty locations, such as boat and RV storage and commercial/industrial buildings.



**Quality  
Guaranteed**

One-year door warranty. For paint, 35-year no-fade, 40-year film integrity.

COMMERCIAL



## Features

- » **Pre-Lubricated Springs**  
During production, springs are factory lubricated and enclosed in a tube to protect them from the environmental elements.
- » **Dead Axle & Barrel Assembly**  
An enclosed spiral barrel houses the dead axle assembly and offers durability and smoother operation as weight is distributed throughout the barrel.
- » **Ratchet Tensioning Device**  
Allows you to simultaneously fine tune springs due to the eight different positions on the tension wheel, which provides equal pull on the left and right sides to ensure balanced operation of the door.
- » **26-Gauge Corrugated Door Curtain**  
Manufactured from galvanized grade 80 steel and coated with super durable polyester paint in more than 30 color options.
- » **Insulated Version Available**  
Side and top draft stops included.

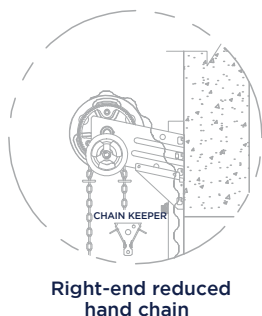
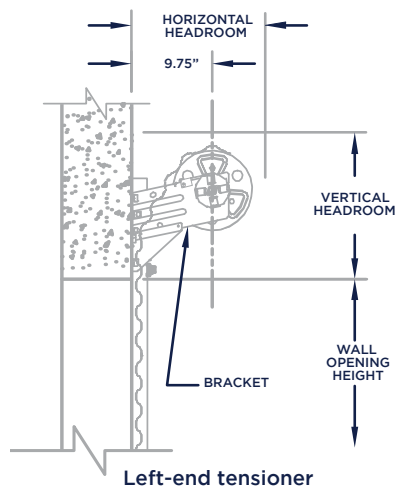

## IMPORTANT NOTES:

- Dimensions are referenced from edge of opening.
- Tensioner end and drive end can be installed at either end of door assembly.
- FOR CRITICAL FITS DUE TO REDUCED AVAILABLE HEADROOM or SIDEROOM CLEARANCES, CONSULT FACTORY.

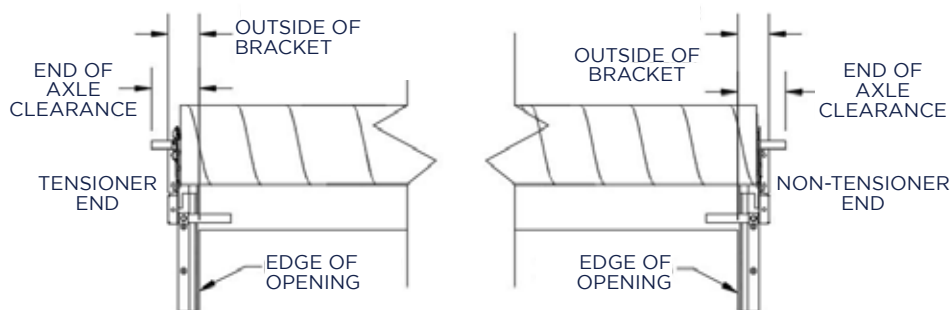

## Guide Details

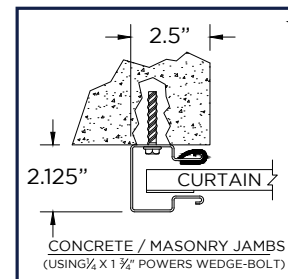
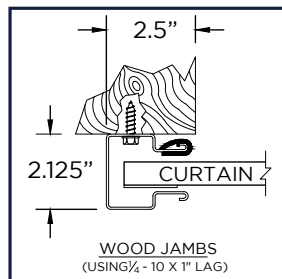
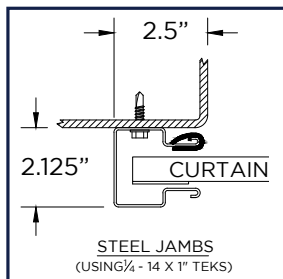

## SPECIFICATIONS

### Side Room Requirements

Operation	Guide	Outside of Bracket Tensioner End	Outside of Hand Chain Drive	Outside of Bracket Drive End	Each End of Axle
Push Up	2.5"	4"	N/A	4"	4"
Reduced Drive Chain	2.5"	4"	5.5"	4"	4"
Electric	2.5"	4"	N/A	4"	4"

### Head Room Requirements

Opening Height	Vertical Headroom	Horizontal Headroom
Thru 8'0"	18"	17.5"
Over 8'0" thru 10'0"	18.5"	17.75"
Over 10'0" thru 12'0"	18.75"	18"
Over 12'0" thru 14'0"	19"	18.5"

## HIGHLIGHTS:

- B** Barrel: 9.5"
- G** Guide: 2.25", 16-gauge
- Ⓢ** 4:1 reduced-drive chain hoist offers smoother operation on doors over 10' tall.

Visit [rollupdoorsdirect.com](http://rollupdoorsdirect.com) for technical drawings, color options and more.

Universal mount 2.25" deep 16-gauge galvanized steel guides require no pre-installation modifications for wood, steel, concrete or filled masonry block applications. Guides have deeper engagement, which allows the curtain to stay in place under more severe wind conditions.